

Creating Convex Edges



1

Create the Primary Bevel

The first decision to make is what angle you would like for the final cutting edge. This is the intersection of the bevels at the very edge of the knife that will do all the cutting work. Depending on the steel of the blade and the way you plan to use the knife, you may want to go with a lower or higher angle. For the purposes of this instruction sheet, let's assume that the knife is a medium quality stainless steel chef's knife, designed mostly for chopping vegetables. For a knife like this, you might choose 20° per side as the final angle. (If you weren't going for a convex grind, you would have flat bevels, otherwise known as a V grind and your blade would look like fig. 1.)

fig. 1

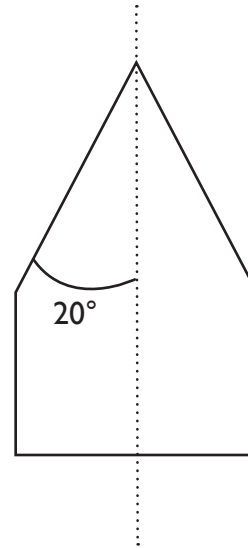

In order to create a convex edge, you'll first need to create a primary bevel that is more narrow than your final bevel. Begin by setting the Collar of each Guide Rod to 18° and tighten the thumbscrews. Use the coarse stones to grind the bevels until they reach from the shoulder to the edge. When the scratches of the stones appear to reach the edge, concentrate on one side until you are able to detect a burr using your fingernail or cotton swab. Then switch sides and repeat, working until you are able to raise a burr on the opposite side as shown in fig. 2.

fig. 2

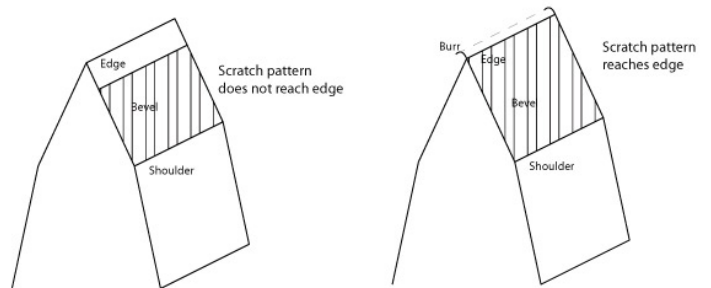

2

Polish the Primary Bevel

Once you've been able to raise a burr along the entire length of the blade, first on one side, then on the other, switch to the next finer grit and begin polishing out the scratches from the previous stone. You will feel the particles of the stone encountering the peaks and valleys of the scratches created by the previous stone. As you polish, the peaks will be ground off and each stroke with the stones will become smoother. When you no longer detect any improvement with each successive stroke, it is time to switch grits. Progress through all the stones until you achieve the level of polish desired.

Creating Convex Edges



3

Create the Secondary Bevel

Now that your primary bevel is polished, move the Collars on each side out to 19° and tighten the thumbscrews. Use your finest stones with alternating strokes to create a bevel on each side that extends approximately $1/3$ the distance down the primary bevel toward the the shoulder. See fig. 3

fig. 3

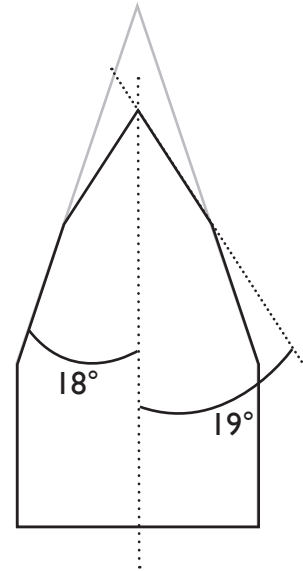
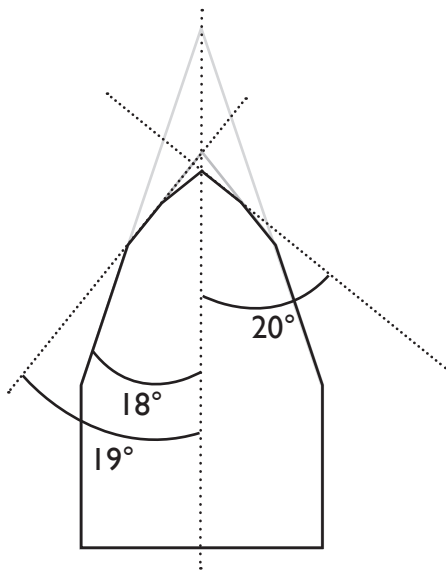

fig. 4



4

Create the Final Bevel

Now that your secondary bevel is created, move the Collars on each side out to 20° and tighten the thumbscrews. Use your finest stones with alternating strokes to create a small bevel on each side. Do not spend more time than necessary to create a bevel that is just visible to the eye. See fig. 4.

fig. 5

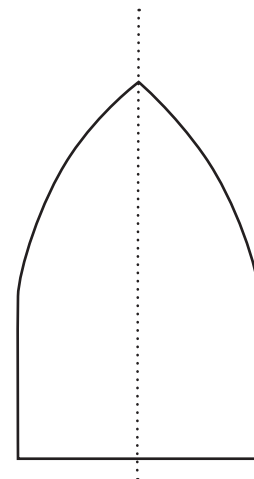

5

Blend the Bevels Together

When your final bevel is complete, clean the blade thoroughly to remove any metal fouling and debris. Move the Collars on each side in to 18° and tighten the thumbscrews. Use alternating strokes with your coarses strops to blend each of the bevels together to finish creating your convex edge. See fig. 5.

Strop the blade at the most narrow angle (in this case 18°) to maintain it.